

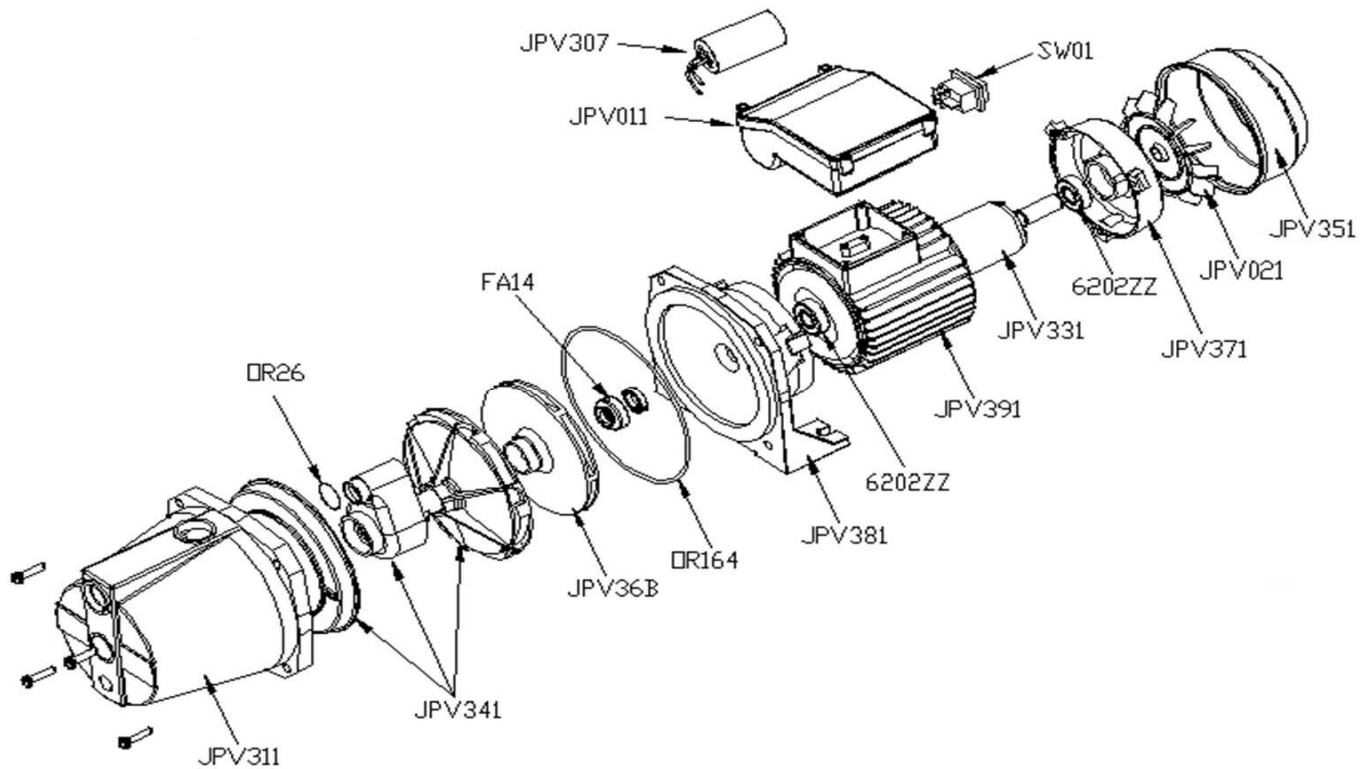









JPV 1300 B



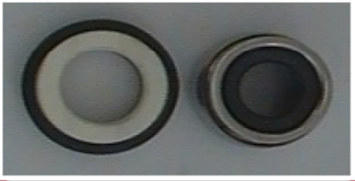

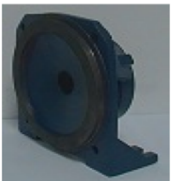

No	Code	Name	Qty	No	Code	Name	Qty
1	026016	Pump case	1	25	029974	Combined stator	1
2		Screw	1	26		Base	1
3		„O” ring 13*2,5	1	27		Corrugated washer	1
4		Screw	1	28	029972	Rear badge plate	1
5		„O” ring 12*2	1	29		Screw	3
6		Plastic cap	2	30		Washer	3
7	026017	Anti-spinning piece	0	31	026023	Fan	1
8		„O” ring 26*2	1	32	026024	Fan enclosure	1
9	026018	Diffuser	1	33	026025	Condenser housing	1
10	026019	Impeller	1	34		Screw	6
11		Screw nut	1	35		„O” ring 140*1,5	1
12		Washer	1	36	029868	Switch	1
13		Washer	1	37		Condenser	1
14		Key	1	38		„O” ring 32*2,5	1
15	026020	Axial gasket	1	39		Condenser fixing	1
16	026021	„O” ring 164*3,5	1	40		Cable shoe	8
17		Diffuser	1	41		Shrinkable tube	8
18	026022	Motor front badge plate	1	42		Connection terminal	1
19		Screw	2	43		Screw nut	6
20		Washer	2	44		Washer	6
21		Screw	2	45		Screw	7
22	010771	Bearing	2	46		Washer	4
23		Handgrip	1	47		Washer	1
24	029973	Rotor	1	48		Washer	1

JPV 1300 B - parts that can be ordered

Serial no.	Description	Note	Picture
1	Pump case	Cast iron case, with 1" connections	
7	Anti-spinning piece	Anti-spinning piece missing from older models	
8	„O” ring 26*2	Sealing ring in the suction part of the injector	
9	Diffuser	Plastic element in the pump case, with anti-spinning piece	
10	Impeller	Ø 130 mm, 6-blade plastic impeller. Blade height: 6.2 mm	
15	Axial gasket	Ceramic-insert gasket for the 14 mm shaft	
16	„O” ring 164*3,5	Gasket between the pump case and the motor front badge plate	
18	Motor front badge plate	Motor badge plate on the drive side	
22	Bearing	Ball bearing	

JPV 1300 B - parts that can be ordered

Serial no.	Description	Note	Picture
23	Handgrip	Bent steel lug	
24	Rotor	249 mm shaft length, with Ø54.4 mm, 86mm long iron core	
25	Combined stator	1300 W coil, with Ø 110 mm, 85mm long iron core, in finned aluminium housing	
28	Rear badge plate	Aluminium badge plate on the side opposite to the drive	
31	Fan	Plastic fan blade, on spliced shaft	
32	Fan enclosure	Cooling fan enclosure	
33	Condenser housing	Plastic cabinet containing electric fittings	
36	Switch	16A/250V red switching key	
37	Condenser	16uF/400V condenser	