

**TAVOLA RICAMBI  
TABLEAU PIECES DETACHEES  
SPARE PARTS TABLE  
ERSATZTEILTAFEL  
TABLA DE REPUESTOS  
TÁBUA PEÇAS DE TROCA**

**6LD325  
6LD360  
6LD400  
6LD435  
K-AGR.**

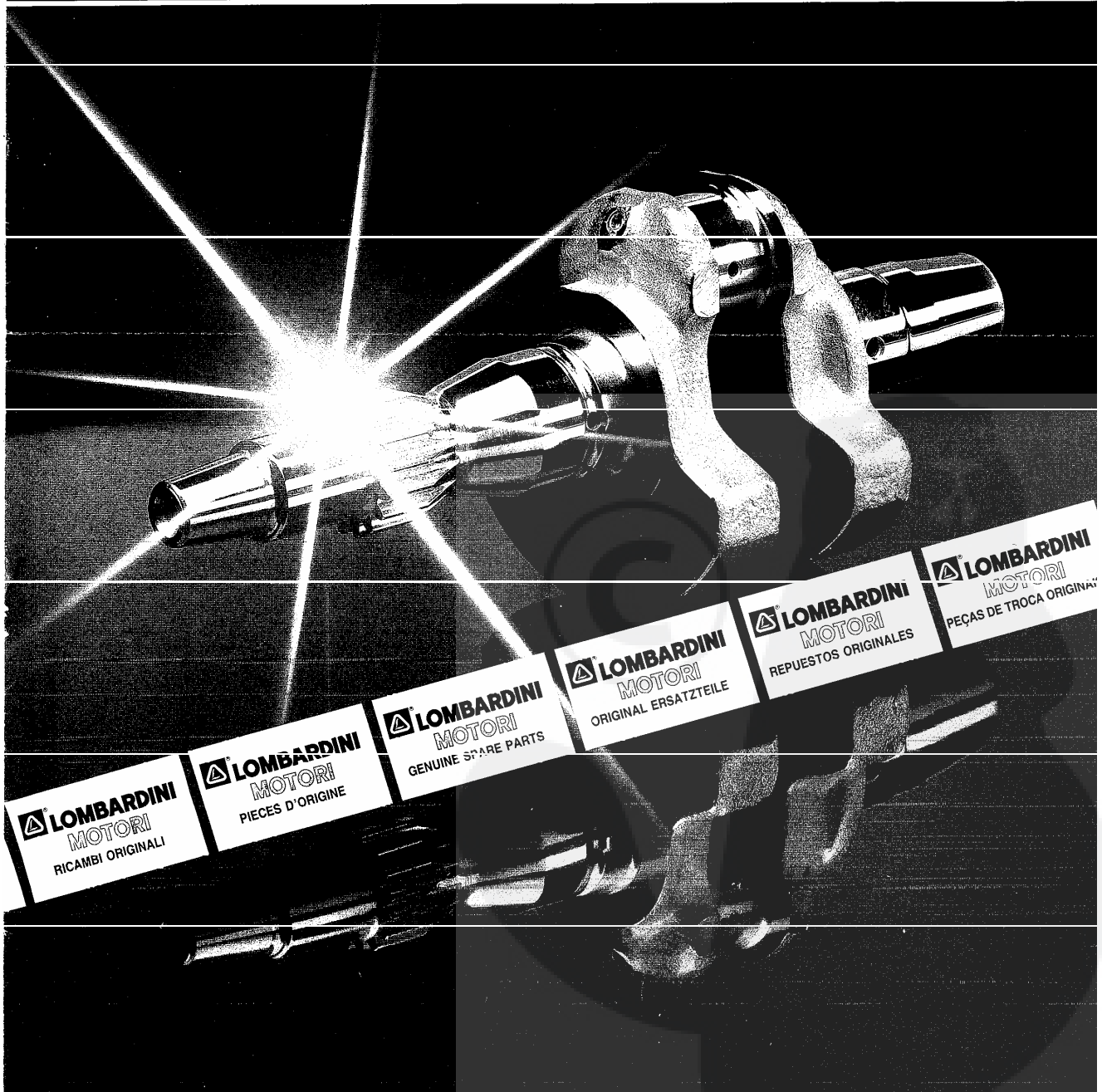

**RICAMBI**  
**PIECES**  
**SPARE PARTS**  
**ERSATZTEILE**  
**REPIESTOS**  
**RECÁMBIOS**

**RICAMBI PER MOTORE STANDARD.**  
**PER APPLICAZIONI SPECIALI**  
**CONSULTARE IL CATALOGO PRESSO I**  
**CENTRI ASSISTENZA E RICAMBI.**

**PIECES POUR DES MOTEURS**  
**STANDARD.**  
**POUR LES ADAPTATIONS CONSULTER**  
**LE CATALOGUE AUPRES DES AGENTS**  
**SERVICE.**

**SPARE PARTS FOR STANDARD**  
**ENGINE.**  
**FOR SPECIAL APPLICATIONS SEE**  
**MASTER CATALOG AT SERVICE**  
**CENTERS.**

**A**

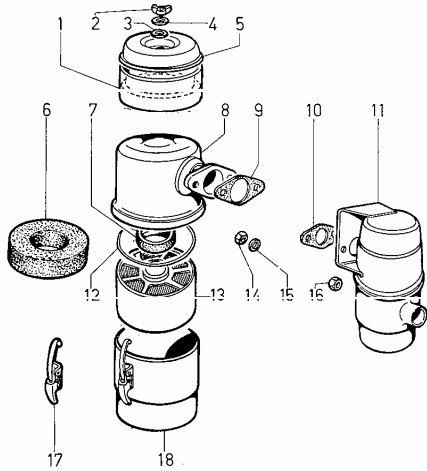

**B**

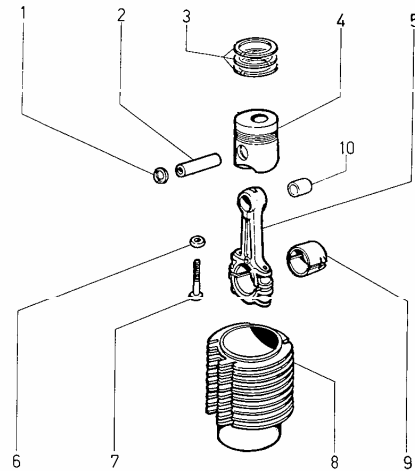

**E**

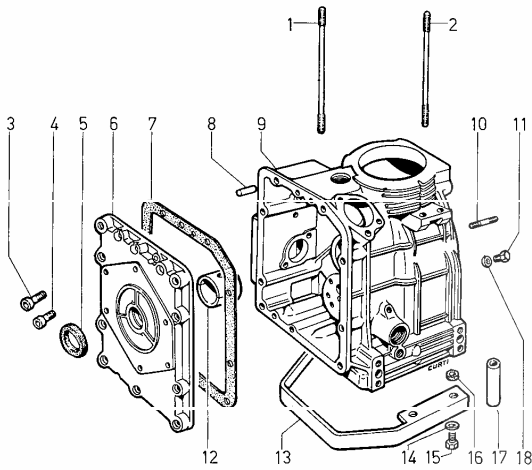

**F**

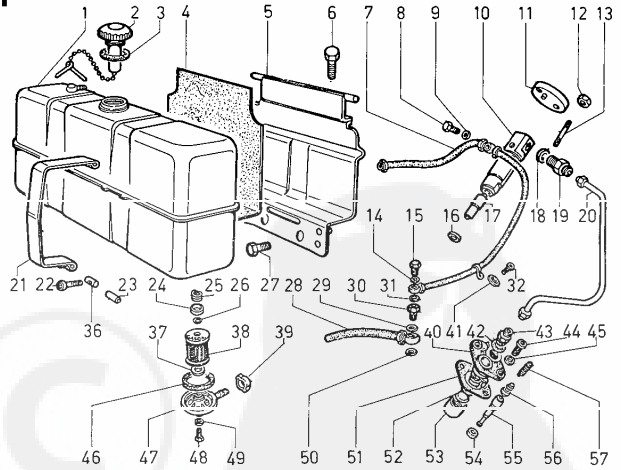

**I**

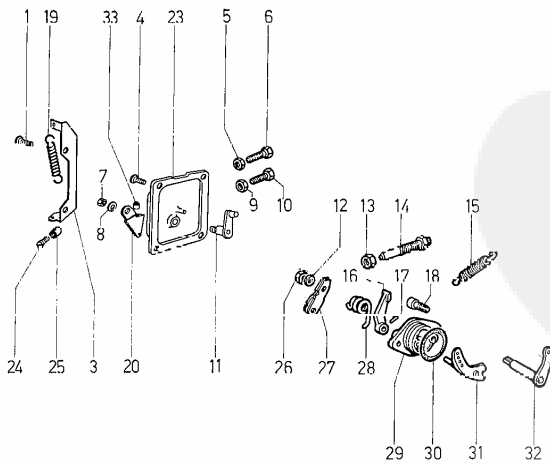

**L**

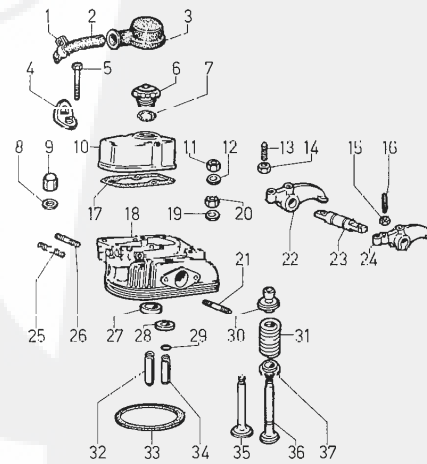

ERSATZTEILE FÜR STANDARD-MOTOREN.  
FÜR SONDERANFERTIGUNGEN SIEHE  
ERSATZTEILKATALOG BEI SERVICE  
WERKSTÄTTEN.

REPUESTOS PARA MOTORES  
STANDARD.  
PARA APLICACIONES VEASE  
CATALOGO EN LAS ESTACIONES  
SERVICE.

PEÇAS DE TROCA PARA MOTOR  
STANDARD.  
PARA APLICAÇÕES ESPECIAIS  
CONSULTAR O CATÁLOGO NOS  
CENTROS DE ASSISTÊNCIA E PEÇAS  
DE TROCA.

**GRUPPO**

**6**

**K - AGR.**

**Matricola 1.5302.426**

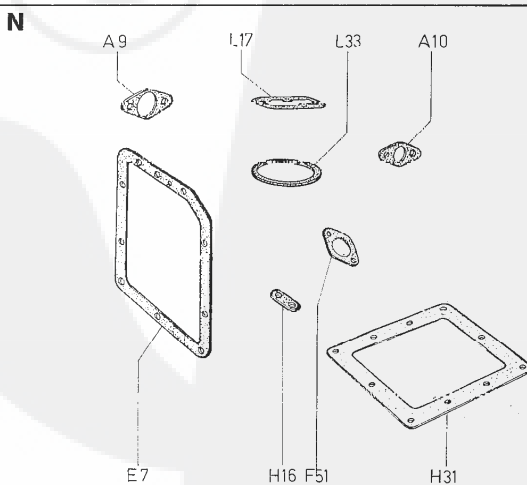
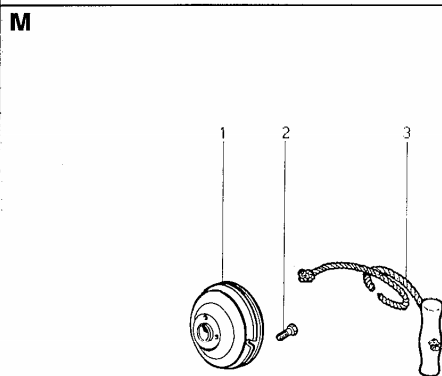
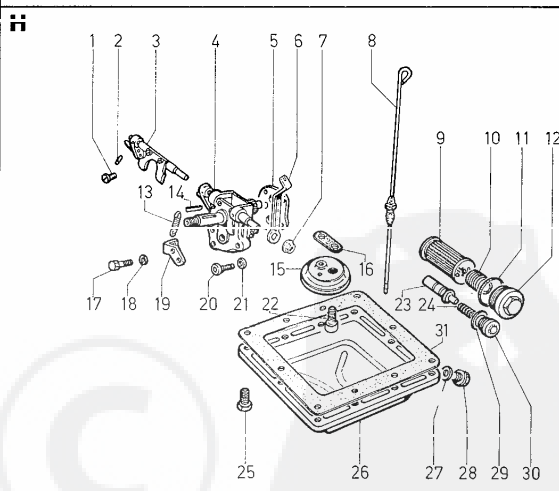
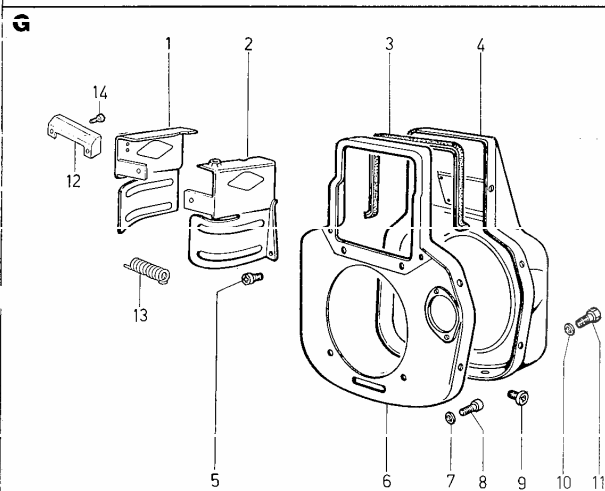
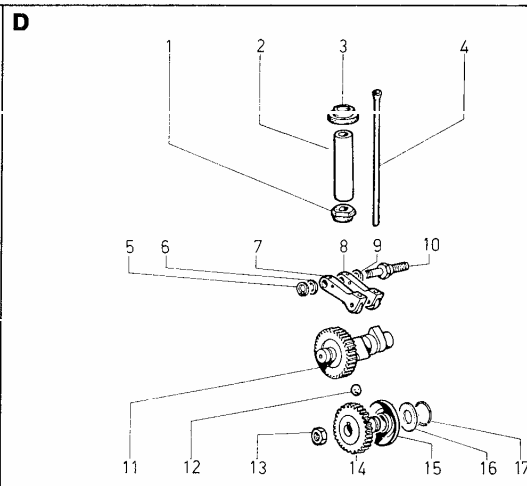
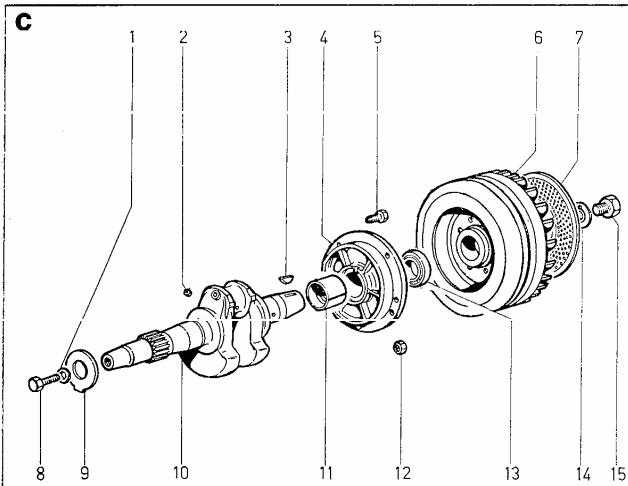

**SERVICE**

Per assistenza e ricambi rivolgersi a stazioni di servizio autorizzate Lombardini. N. tel. su libretto service e su pagine gialle.  
 Pour toute exigence de service après vente et pièces détachées, s'adresser aux Stations de service du réseau Lombardini. N. de téléphone indiqué sur brochure relative au service après vente et annuaire catégorique.  
 For spare parts and after sale assistance contact authorized Lombardini service centers. Tel. No. appears on service booklet and telephone directory.  
 Für Service und Ersatzteile bitten wir, sich an autorisierte Werkstätte zu wenden. Telef. Nummer laut unserem Service - Büchlein und Fernsprechbuch.  
 Para asistencia y repuestos, dirigirse a las estaciones de servicio autorizadas Lombardini. N. Tel. su libretto service y su hojas amarillas.  
 Para assistência e recâmbios dirigir-se às estações de serviço autorizadas Lombardini. Número telefone é sobre a caderneta de serviço e sobre as páginas amarelas.

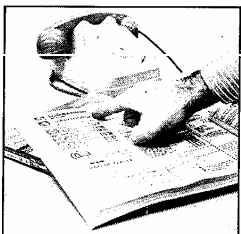
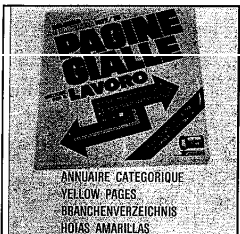
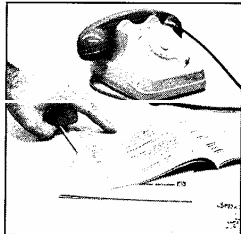
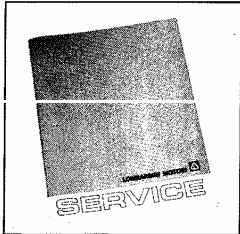

ORDINI RICAMBI  
 COMMANDES PIECES  
 PART ORDERS  
 E-TEIL BESTELLUNGEN  
 PEDIDOS DE REPUESTOS  
 PEDIDOS RECÂMBIOS

TIPO MOTORE  
 TYPE DE MOTEUR  
 ENGINE TYPE  
 MOTORTYP  
 TIPO DEL MOTOR  
 TIPO DE MOTOR

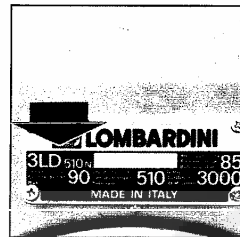
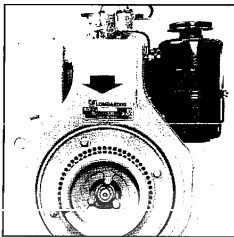

MATRICOLA  
 MATRICULE  
 SERIAL NUMBER  
 MOTORENNUMMER  
 NUMERO DEL MOTOR  
 NUMERO DO MOTOR

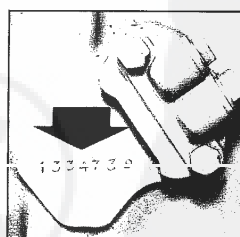
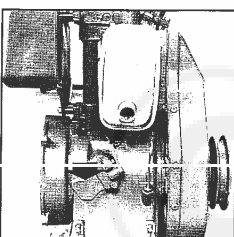
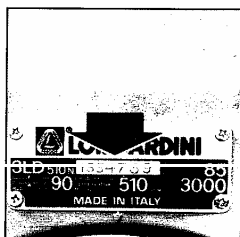
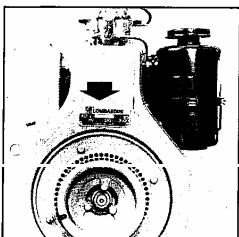

TIPO DELLA MACCHINA  
 TYPE DE MACHINE  
 EQUIPMENT TYPE  
 MASCHINENTYP  
 MODELO DE LA MAQUINA  
 TIPO DA MÁQUINA

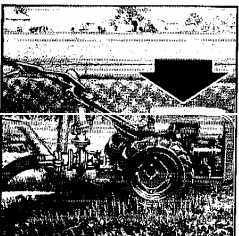

MATRICOLA del ricambio  
 REFERENCE de la pièce  
 SPARE PART number  
 BESTELLNUMMER des Teiles  
 REFERENCIA del repuesto  
 REFERÈNCIA do recâmbio

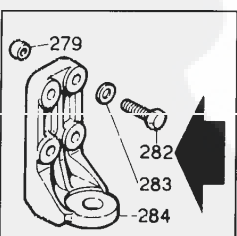
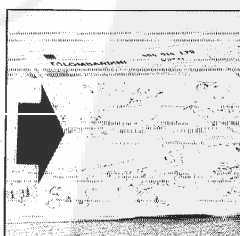

FABBRICA ITALIANA MOTORI S.p.A.  
 42100 REGGIO EMILIA, ITALIA - CAS. POST. 105 - Tel. (0522) 3891 - Teleg.: LOMBARMOTOR - Telex: 530003 MOTLOM I

LOMBARDINI USA  
 LOMBARDINI FRANCE  
 LOMBARDINI MOTOREN GMBH  
 LOMBARDINI MOTORES

2150 Boggs Road Bldg. 300, Suite 300 - Duluth, GA 30136, USA  
 Zone Industr. Nord. Arnas - Villefranche S/Saône, France  
 Berner Str. 54, 6000 Frankfurt/Main 58, Deutschland  
 Zona Cova Solera - Rubí/Barcelona, España

Matricola 1.5302.426

Mod. 50668
5-1992
Subject to alteration
Printed in Italy





**LOMBARDINI**

Gr. 6  
K - AGR.

TAVOLA RICAMBI SPARE PARTS TABLE TABLEAU PIECES DETACHEES. 1.5302.426

\*\*\*\*\*

Maggio/May/Mai 1992

\*\*\*\*\*

MOTORI/ENGINES/MOTEURS Gr. 6 K - AGR.  
MOTOZAPPA, MOTOCOLTIVATORE, MOTOFALCIATRICE  
MOTORHOE, MOTORCULTIVATOR, MOTOR MOWER  
MOTOHOUE, MOTOCULTEUR, MOTOFAUCHEUSE

Colonna/Cóolumn/Colonne	1	=	6LD 325 K - AGR.	Version std.	710104
"	"	"	2 = 6LD 360 K - AGR.	"	722072
"	"	"	3 = 6LD 400 K - AGR.	"	718892
"	"	"	4 = 6LD 435 K - AGR.	"	727690

Vedi/See/Voir

Libretto Uso e Man./Use-Maint.booklet/Livret Emploi-Entret. ....	1.5302.385
Libretto Service/Service directory/Reseau S.A.V. ....	1.7968.002
Serie accessori/Accessory set/Jeu accessoires .....	283.8140.080

note/remarks/remarques

- F - alta movimentazione/fast moving part/haut mouvement.
- S - media movimentazione/medium moving part/moyen mouvement.
- D - bassa movimentazione/slow moving part/bas mouvement.
- E - ad esaurimento/exhausting part/pièce en epuisement.
- N - particolare nuovo o fornito su richiesta/  
-new part or part supplied upon request/  
-pièce nouvelle ou fournie sur demande.
- A - valido dal motore.../from eng.S.No.../à partir du moteur... \*
- B - valido fino al motore.../up to eng.S.No.../jusqu'au moteur... \*
- I - intercambiabile/interchangeable. \*
- \* (vedi Circolare Tecnica/see Service Letter/voir Circ.Techn.)
- V - stock per Off.Service/stock for Service Dealer/stock pour Stations Service
- C - stock vitale per Costruttori,Esportatori,Enti di Stato.  
vital stock for Producers,Exporters,State Companies.  
stock vital pour Constructeurs,Export.,Institut.de l'Etat.
- R - stock Rettif./Grinding Workshops stock/stock pour Usines de Rectification
- 10/50/2-q.ta minima fornibile/min.supplied q.ty/q.te min.fournie.
- = gruppo completo/assembly/groupe complet.
- + componente del gruppo/assembly component/composant du groupe.

Serie guarnizioni/Gasket set/Jeu de joints . 6LD 325 .....	520.8180.092
6LD 360 .....	530.8180.082
6LD 400-6LD 435 .....	540.8180.063

Descrizioni non impegnative/Subject to modifications/Modifications réservées  
TECO/ALL/Assistenza tecnica Lombardini/maggio 1992

Riquadro/Drawing/Dessin A ASPIRAZIONE E SCARICO INTAKE AND EXHAUST ADMISSION ET ECHAPPEMENT	Riquadro/Drawing/Dessin G RAFFREDDAMENTO COOLING SYSTEM CIRCUIT DE REFROIDISSEMENT
Riquadro/Drawing/Dessin B CILINDRO, BIELLA E PISTONE CYLINDER, CONNECTING ROD AND PISTON SET CYLINDRE, BIELLE ET PISTON	Riquadro/Drawing/Dessin H CIRCUITO DI LUBRIFICAZIONE LUBRICATING SYSTEM CIRCUIT DE LUBRIFICATION
Riquadro/Drawing/Dessin C ALBERO A GOMITO, SUPPORTO E VOLANO CRANKSHAFT, FLYWE.SIDE SUPPORT AND FLYWHEEL VILEBREQUIN, PALIER ET VOLANT	Riquadro/Drawing/Dessin I COMANDI CONTROLS COMMANDES
Riquadro/Drawing/Dessin D DISTRIBUZIONE E REGOLATORE DI GIRI TIMING AND SPEED GOVERNOR DISTRIBUTION ET REGULATEUR DE VITESSE	Riquadro/Drawing/Dessin L TESTA, CAPPELLO BILANCIERI E VALVOLE CYLINDER HEAD, ROCKER ARM BOX AND VALVES CULASSE, COUV. CULBUTEURS ET SOUPAPES
Riquadro/Drawing/Dessin E BASAMENTO, PORTINA LATO DISTRIBUZIONE E PIEDI CRANKCASE, COVER GEAR AND MOUNTS CARTER MOTEUR, CARTER COTE DISTRIB., PIEDS	Riquadro/Drawing/Dessin M AVVIAMENTO STARTING DEMARREUR
Riquadro/Drawing/Dessin F CIRCUITO COMBUSTIBILE FUEL SYSTEM CIRCUIT CARBURANT	Riquadro/Drawing/Dessin N COMPOSIZIONE SERIE GUARNIZIONI/ANELLI GASKET/O RING SET COMPOSITION COMPOSITION SERIE JOINTS/BAGUES



Pos.	Matricola/Part No.	Note/Remarks	Q.ty/Eng.	
A 1+	1301.053	500 FV C 10	prefiltro/prefilter	1 1 1 1
A 2+	3200.002	9 FV C 10	dado/nut	1 1 1 1
A 3+	4775.137	9140 N 10	guarnizione/gasket	1 1 1 1
A 4+	7625.092	9 D C 10	rondella/washer	1 1 1 1
A 5+	2125.055	500 F C	cappello prefiltro/prefilter cover	1 1 1 1
A 6+	5496.113	500 SV C	massa filtr./filt.element Diam.=124	1 1 1 1
A 7+	1261.072	500 FV C 10	anello/seal ring H=17,6 Diam.= 54	1 1 1 1
A 8	=3700.109	540 FV C	FILTRO ARIA/AIR CLEANER (Pos. 1-2-3-4-5-6-7-8-12-13-17-18)	1 1 1 1
A 9	4500.092	500 FV C 10	guarnizione/gasket	1 1 1 1
A 10	4500.091	500 FV C 10	guarnizione/gasket	1 1 1 1
A 11	5462.089	500 F C	marmitta/muffler	1 1 1 1
A 12+	4775.120	500 FV C 10	guarnizione/gasket H=10 Diam.=135	1 1 1 1
A 13+	5496.071	500 SV C	massa/filt.element H=90 Diam.=119	1 1 1 1
A 14	3240.018	9 FV 10	dado/nut	2 2 2 2
A 15	7565.007	9 F C 10	rondella/washer	2 2 2 2
A 16	3240.095	9 FV C 10	dado/nut	2 2 2 2
A 17+	4115.048	276 F C 10	gancio/hook	2 2 2 2
A 18+	.....	.	vedi/see Pos. 8	
B 1+	1240.017	9 FV C 10	anello seeger/snap ring	2 2 2 2
B 2+	8480.075	530 S IC	spinotto/gudgeon pin	1 1 1 1
"	8480.060	540 D IC	"	
B 3+	8211.078	520 FV C	serie segmenti/ring set std.	1 1 1 1
"	8211.079	520 F CR	" " +0,50	1 1 1 1
"	8211.080	520 F CR	" " +1,00	1 1 1 1
"	8211.045	530 FV C	" " std.	1 1 1 1
"	8211.046	530 F CR	" " +0,50	1 1 1 1
"	8211.047	530 F CR	" " +1,00	1 1 1 1
"	8211.056	540 FV C	" " std.	1 1 1 1
"	8211.017	540 F CR	" " +0,50	1 1 1 1
"	8211.018	540 F CR	" " +1,00	1 1 1 1
B 4	=6500.808	520 FVAC	PISTONE COMPLETO/PISTON SET std.	1 1 1 1
"	=6500.809	520 F ACR	" " +0,50	1 1 1 1
"	=6500.810	520 F ACR	" " +1,00	1 1 1 1
"	=6500.733	530 FVAC	" " std.	1 1 1 1
"	=6500.734	530 F ACR	" " +0,50	1 1 1 1
"	=6500.735	530 F ACR	" " +1,00	1 1 1 1
"	=6500.730	540 FVAC	" " std.	1 1 1 1
"	=6500.731	540 F ACR	" " +0,50	1 1 1 1
"	=6500.732	540 F ACR	" " +1,00	1 1 1 1
"	=6500.811	550 FV C	" " std.	1 1 1 1
"	=6500.812	550 F CR	" " +0,50	1 1 1 1
"	=6500.813	550 F CR	" " +1,00	1 1 1 1
			(Pos. 1-2-3-4)	
B 5	=1526.030	500 F C	BIELLA COMPLETA/CONNECTING ROD (Pos. 5-6-7)	1 1 1 1
"	=1526.135	550 F C	BIELLA COMPLETA/CONNECTING ROD (Pos. 5-6-7-10)	1 1 1 1
B 6+	7626.048	9 S C 10	rondella/washer	2 2 2 2
B 7+	1770.083	9 FV C 10	bullone/bolt M 8 X 1,25 X 50	2 2 2 2
H 8	2380.299	520 FVAC	cilindro/cylinder	1 1 1 1
"	2380.275	530 FVAC	"	
"	2380.298	540 FVAC	"	
"	2380.461	550 FV C	"	
B 9	1640.066	360 FV C	bronz.biella/large end bushing std.	1 1 1 1
"	1640.067	360 F CR	" " -0,25	1 1 1 1
"	1640.068	360 F CR	" " -0,50	1 1 1 1
B 10+	1630.010	500 SV CR	bronz.piede/small end bushing	1 1 1 1
C 1	7625.060	9 S C 10	rondella/washer	1 1 1 1
C 2+	9000.069	500 S 10	tappo/expansion plug	2 2 2 2
C 3+	2280.048	9 FV C 10	chiavetta l.vol./flywheel side key	1 1 1 1
C 4	8675.135	500 F AC	supporto/crankshaft support	1 1 1 1
C 5	1760.001	9 FV 10	bullone/bolt M 6 X 1 X 10	4 4 4 4
C 6	9882.027	5000 N	vol.lmp.luce/light.syst.flywheel	1 1 1 1
"	9880.305	540 N	"	
"	9880.129	540 N A	"	
Motore/Engine			6LD 325 K - AGR. Versione/Version 710104	
" " " " " " " " " " " "			6LD 360 K - AGR. " " 722072	
" " " " " " " " " " " "			6LD 400 K - AGR. " " 718892	
" " " " " " " " " " " "			6LD 435 K - AGR. " " 727690	



Pos.	Matricola/Part No.	Note/Remarks	Q.ty/Eng.
C 7	5095.076 500 F C	lamiera/panel	1 1 1 1
C 8	1770.039 9 S C 10	bullone/bolt M 8 X 1,25 X 28	1 1 1 1
C 9	1257.008 500 FV C 10	anello reggispinta/thrust washer	1 1 1 1
C 10	=1050.115 500 F C	ALBERO GOMITO/CRANKSHAFT (con.300 mm)	1 1 1 1
"	=1050.669 550 S C	" " " "	1
		(Pos. 2-3-10)	
C 11	1611.012 500 FV C	br.l.volano/flywheel side bear. std.	1 1 1 1
"	1611.013 500 F CR	" " " -0,50	1 1 1 1
"	1611.014 500 F CR	" " " -1,00	1 1 1 1
C 12	3203.047 9 FV C 10	dado/nut	5 5 5 5
C 13	1210.092 9 FV C 10	anello tenuta/seal ring	1 1 1 1
C 14	7626.043 9 S C 10	rondella/washer	1 1 1 1
C 15	1800.030 9 F C 10	bullone/bolt	1 1 1 1
D 1	4740.025 500 FV C 10	guarnizione/lower gasket	1 1 1 1
D 2	9520.029 500 FVIC	TUBO PROTEZ./GUARD TUBE	1 1 1 1
D 3	4740.018 500 FV C 10	guarnizione/upper gasket	1 1 1 1
D 4	1410.016 500 FV C	asta punteria/push rod	2 2 2 2
"	1410.105 550 FV C	" " " "	2
D 5	1240.004 9 FV C 10	anello seeger/snap ring	1 1 1 1
D 6	7550.006 500 S C 10	rondella/washer	1 1 1 1
D 7	5271.054 500 F C	leva/lever	1 1 1 1
D 8	5271.054 500 F C	leva/lever	1 1 1 1
D 9	7550.006 500 S C 10	rondella/washer	1 1 1 1
D 10	6140.080 500 S C 10	perno/pin	1 1 1 1
D 11	1011.151 500 F C	albero camme/camshaft	1 1 1 1
D 12+	8245.009 9 F AC 10	sfera/ball (7/16"- mm 11,112)	6 6 6 6
D 13	3203.060 9 FV C 10	dado/nut	1 1 1 1
D 14	=7362.193 500 S AC	REGOLATORE DI GIRI/SPEED GOVERNOR (Pos. 12-14-15-16-17)	1 1 1 1
D 14+	4936.020 500 F AC	ingranaggio/gearwheel	1 1 1 1
D 15+	2086.100 500 S A	campana/governor bell (polyamid)	1 1 1 1
D 16+	7701.081 500 N A 10	rondella/thrust washer	1 1 1 1
D 17+	1160.011 500 DV C 10	anello/circlip	1 1 1 1
E 1+	6850.108 540 SV C	prig.lato distr./gear side stud	2 2 2 2
"	6850.182 550 SV C	" " " " " " " "	2
E 2+	6850.106 540 SV C	prig.lato volano/flywheel side stud	2 2 2 2
"	6850.181 550 SV C	" " " " " " " "	2
E 3	9732.063 9 S C 10	vite/screw M 8 X 1,25 X 35	9 9 9 9
E 4	9732.064 9 S 10	vite/screw M 8 X 1,25 X 30	1 1 1 1
E 5+	1213.056 9 FV C 10	anello tenuta/seal ring	1 1 1 1
E 6	=6645.220 530 F C	PORTINA DISTRIB./CASE COVER (Pos. 5-6)	1 1 1 1
F 7	4601.020 500 FV C 10	guarnizione/gasket 0.25	1 1 1 1
E 8+	8460.055 276 D C 10	spina/taper pin	2 2 2 2
E 9	=1510.216 520 D C	BASAMENTO/CRANKCASE	1
"	=1510.171 540 S C	" " " "	1 1
"	=1510.531 550 N	" " " "	1
		(Pos. 1-2-8-9-10)	
E 10+	6780.076 9 FV C 10	prigioniero/stud M 8 X 18 (34)	5 5 5 5
E 11	1770.001 9 D C 10	bullone/bolt M 8 X 1,25 X 12	1 1 1 1
E 12	1611.018 530 FV C	br.l.distrib./gear side bearing std.	1 1 1 1
"	1611.019 530 F CR	" " " " -0,50	1 1 1 1
"	1611.020 530 F CR	" " " " -1,00	1 1 1 1
E 13	6010.066 5000 N	pattino/guard pad	1 1 1 1
"	6010.075 550 N	" " " "	1
E 14	7625.012 9 FV C 10	rondella/washer	4 4 4 4
E 15	1770.007 9 F C 10	bullone/bolt	4 4 4 4
"	9730.100 9 F 10	vite/screw M 8 X 1,25 X 25	4 4 4 4
E 16	3527.004 720 F 10	distanziale/spacer	4 4 4 4
E 17	2500.094 5000 N	colonna/hallowstud	4 4 4 4
E 18	4670.058 9 FV C 10	guarnizione/copper gasket	1 1 1 1
Motore/Engine 6LD 325 K - AGR. Versione/Version 710104 .....			
" " 6LD 360 K - AGR. " " 722072 .....			
" " 6LD 400 K - AGR. " " 718892 .....			
" " 6LD 435 K - AGR. " " 727690 .....			
LOMBARDINI MOTORI F.I.M. S.p.a.			Edizione del/Issue of 15.05.1992



Pos.	Matricola/Part No.	Note/Remarks	Q.ty/Eng.
F 1	=8103.038 500 F C	SERBATOIO/FUEL TANK (Pos. 1-2-3)	1 1 1 1
F 2	= 9043.025 2830 FV C	TAPPO SERBATOIO/FUEL TANK CAP (Pos. 2-3)	1 1 1 1
F 3+	4650.056 2700 DV C 10	guarnizione/gasket	1 1 1 1
F 4	4701.010 500 FV C 10	guarnizione/gasket	1 1 1 1
F 5	8866.053 500 F C	suppl.dist./gear side tank support	2 2 2 2
F 6	1770.111 9 F C 10	bullone/bolt	1 1 1 1
F 7	3601.064 530 FV C 10	tubo sgrugo/bleeding pipe (mm 530)	1 1 1 1
F 8	1901.029 9 FV C 10	bullone raccordo/connection bolt	1 1 1 1
F 9	4670.058 9 FV C 10	guarnizione/copper gasket	2 2 2 2
F 10	=6615.043 540 S C	PORTAPOLVERIZZATORE/NOZZLE-HOLDER (Pos. 10-17-18-19)	1 1 1 1
F 11	3790.042 500 S C	flangia/flange	1 1 1 1
F 12	3203.050 9 N 10	dado/nut	2 2 2 2
F 13+	6760.035 9 FV C 10	prigioniero/stud M 6 X 53 (65)	2 2 2 2
F 14	4670.058 9 FV C 10	guarnizione/copper gasket	1 1 1 1
F 15	1901.029 9 FV C 10	bullone raccordo/connection bolt	1 1 1 1
F 16	4670.065 9 SV C 10	guarnizione/copper gasket 1,50	1 1 1 1
F 17+	6531.104 395 FV C	polverizzatore/nozzle	1 1 1 1
F 18+	4650.037 260 DV C 10	guarnizione/gasket	1 1 1 1
F 19+	7301.006 500 DV C 10	raccordo/connection	1 1 1 1
F 20	9372.090 500 FV C	tubo mandata comb./fuel delivery pipe	1 1 1 1
F 21	=3617.010 500 F C 10	FACSETTA SERB./FUEL TANK STRAP (Pos. 21-22-36)	2 2 2 2
F 22+	9730.016 9 DV C 10	vite/screw M 6 X 1 X 35	2 2 2 2
F 23	9600.057 2/1 FV C 10	tubo/rubber spacer	2 2 2 2
F 24+	3930.019 273 F C 10	fondello/cup	1 1 1 1
F 25+	5575.006 273 FV C 10	molla/spring	1 1 1 1
F 26+	1200.032 9 FV C 10	anello OR/rubber oil seal	2 2 2 2
F 27	1770.111 9 F C 10	bullone/bolt	1 1 1 1
F 28	9375.204 500 FV C	tubo comb./fuel pipe (mm 142)	1 1 1 1
F 29	4670.060 9 FV C 10	guarnizione/copper gasket	1 1 1 1
F 30	1901.012 710 FV C 10	bullone raccordo/connection bolt	1 1 1 1
F 31	4670.058 9 FV C 10	guarnizione/copper gasket	1 1 1 1
F 32	9790.037 9 FV C 10	vite/screw	2 2 2 2
F 36+	1557.019 45 F C 10	blocchetto/nut	1 1 1 1
F 37+	4490.017 273 FV C 10	guarnizione/gasket	1 1 1 1
F 38	=3730.028 500 FV C	FILTRO COMBUSTIBILE/FUEL FILTER (Pos. 24-25-26-37-38-46-47-48-49)	1 1 1 1
F 38+	2175.032 500 FV C	cartuccia comb./fuel filter element	1 1 1 1
F 39	3630.008 9 F C 10	fascetta/clamp	1 1 1 1
F 40	=6590.136 520 D C	POMPA INIEZIONE/INJECTION PUMP	1 1 1 1
"	=6590.133 540 F C	" "	1 1 1 1
"	=6590.102 550 F C	" "	1 1 1 1
		(Pos. 40-42-43)	
F 41	7625.008 9 D C 10	rondella/washer	1 1 1 1
F 42+	1200.031 9 FV C 10	anello OR/rubber oil seal	1 1 1 1
F 43+	7265.008 271 FV C 10	raccordo/connection	2 2 2 2
F 44	9730.100 9 F 10	vite/screw M 8 X 1,25 X 25	2 2 2 2
F 45	7625.010 9 FV C 10	rondella/washer	1 1 1 1
F 46	4431.040 500 FV C 10	guarnizione/gasket	1 1 1 1
F 47	=2605.024 500 F C	COPERCHIO FILTRO/FILTER COVER ASS.Y (Pos. 47-48-49)	1 1 1 1
F 48+	1760.076 9 N	bullone/bolt	1 1 1 1
F 49+	1202.052 9 FV C 10	anello OR/rubber oil seal	1 1 1 1
F 50	4670.060 9 FV C 10	guarnizione/copper gasket	1 1 1 1
F 51	4580.023 500 N 50	guarnizione/gasket 0,30	1 1 1 1
"	4580.024 500 N 50	" " 0,50	1 1 1 1
"	4580.029 500 N 50	" " 0,10	1 1 1 1
"	4580.057 500 N 10	" " 0,10	1 1 1 1
F 52	6000.036 500 FV C 10	pastiglia/tappet	1 1 1 1
F 53	7215.035 500 FV C	punteria/tappet	1 1 1 1
F 54	6400.045 500 SV C 10	piattello/cup	1 1 1 1
Motore/Engine 6LD 325 K - AGR. Versione/Version 710104			
" " 6LD 360 K - AGR. " " 722072			
" " 6LD 400 K - AGR. " " 718892			
" " 6LD 435 K - AGR. " " 727690			





Pos.	Matricola/Part No.	Note/Remarks	Q.ty/Eng.
F 55	6578.041 520 FV C	pompante/plunger 6LD325	1
"	6578.133 540 FV C	pompante/plunger 6LD360-400	1 1
"	6578.162 550 FV C	" " " "	1
F 56	9672.029 540 D C	valvolina/delivery valve (mmc 15)	1
"	9672.012 500 F C	" " " " (mmc 25)	1 1 1 1
F 57	5755.034 271 SV C 10	molla/spring	1 1 1 1
G 1	5066.111 540 N A	lamiera/airtight plate	1 1 1
"	5066.198 550 S C	" " " "	1
G 2	5066.112 340 N A	lamiera/airtight plate	1 1 1
"	5066.199 550 S C	" " " "	1
G 3	4570.010 530 FV C	guarnizione/gasket	1 1 1 1
G 4	2568.086 500 S C	convogliatore/shroud	1
"	2569.058 540 S C	" " " "	1 1 1 1
G 5	9790.037 9 FV C 10	vite/screw M 6 X 1 X 8	2 2 2 2
G 6	6370.154 520 D C	piastra/shroud plate	1
"	6370.118 540 S C	" " " "	1 1
"	6370.266 550 S C	" " " "	1
G 7	.....		
G 8	1770.111 9 F C 10	bullone/bolt M 8 X 1,25 X 18	4 4 4 4
G 9	9790.037 9 FV C 10	bullone/bolt M 6 X 1 X 8	6 6 6 6
G 10	7565.007 9 F C 10	rondella/washer	2 2 2 2
G 11	9731.030 9 D 10	vite/screw M 8 X 1,25 X 12	2 2 2 2
G 12	5055.031 550 N	lamierino/plate	1
G 13	5725.043 540 N A	molla/spring	1 1 1 1
G 14	9865.122 9 N 10	vite/screw	2
H 1	9810.002 9 D C 10	vite/screw	2 2 2 2
H 2	8430.023 9 S C 10	spina/locating pin	1 1 1 1
H 3	6140.351 530 DVAC	perno pompa olio/oil pump pin	1 1 1 1
H 4	=6605.066 530 SVAC	POMPA OLIO/OIL PUMP (Pos. 3-4-5-13-14-17-18-19)	1 1 1 1
H 5+	.....	vedi/see Pos. 4	
H 6	5200.363 500 S AC 10	leva/lever	1 1 1 1
H 7	3203.050 9 N A 10	dado/nut	1 1 1 1
H 8	1400.035 500 F C 10	asta livello/dipstick (mm 385)	1 1 1 1
H 9	2175.019 500 FV C	cartuccia olio/oil filter element	1 1 1 1
H 10	5725.032 500 FV C 10	molla/spring	1 1 1 1
H 11	1200.016 9 FV C 10	anello OR/rubber oil seal	1 1 1 1
H 12	9060.008 500 FV C	tappo filtro/filter cap	1 1 1 1
H 13+	5801.198 540 SVAC 10	molla/spring	1 1 1 1
H 14+	2200.013 9 S C 10	chiavetta/key	1 1 1 1
H 15	1745.002 5000 D C	bulbo/oil strainer	1 1 1 1
H 16	4776.016 500 S C 10	guarnizione/gasket	1 1 1 1
H 17+	9730.009 9 D AC 10	vite/screw M 6 X 1 X 12	1 1 1 1
H 18+	7565.004 9 F AC 10	rondella/washer	1 1 1 1
H 19+	6371.045 500 N A 10	piastra/plate	1 1 1 1
H 20	9730.016 9 DV C 10	vite/screw M 6 X 1 X 35	4 4 4 4
H 21	7565.004 9 F C 10	rondella/washer	4 4 4 4
H 22	9732.047 9 D C 10	vite/screw M 12 X 1,5 X 20	1 1 1 1
H 23	9680.013 560 SV C	valvola pressione/pressure oil valve	1 1 1 1
H 24	5755.049 500 FV C 10	molla/spring	1 1 1 1
H 25	1770.111 9 F C 10	bullone/bolt	6 10 6
"	9730.100 9 F 10	vite/screw M 8 X 1,25 X 25	6
H 26	=6647.046 5000 S C	PORTINA DI FONDO/OTI, PAN	1 1 1
"	=6645.296 550 S C	" " " "	1
		(Pos. 26-27-28)	
H 27+	4670.013 9 FV C 10	guarnizione/copper gasket	1 1 1
"	4670.016 9 FV C 10	" " " "	1
H 28+	8965.032 9 S C 10	tappo/plug	1 1 1
"	8965.005 9 FV C 10	" " " "	1
H 29	4670.088 9 N 10	guarnizione/copper gasket 18X24X1	1 1 1 1
H 30	9070.012 500 S C	tappo valvola/valve cap	1 1 1 1
H 31	4601.003 500 FV C 50	guarnizione/gasket	1
I 1	9790.047 9 FV C 10	vite/screw M 6 X 1 X 16	2 2 2 2
I 2	.....		

Motore/Engine	6LD 325 K - AGR.	Versione/Version	710104
"	6LD 360 K - AGR.	"	722072
"	6LD 400 K - AGR.	"	718892
"	6LD 435 K - AGR.	"	727690



Pos.	Matricola/Part No.	Note/Remarks	Q.ty/Eng.
I 3	8900.338 5000 D A	supporto/support	1 1 1 1
I 4	9790.039 9 FV C 10	vite/screw M 6 X 1 X 12	2 2 2 2
I 5	3240.008 9 FV 10	dado/nut	1 1 1 1
I 6	1760.029 9 D C 10	bullone/bolt M 6 X 1 X 30	1 1 1 1
I 7+	3240.008 9 FV 10	dado/nut	1 1 1 1
I 8+	7565.004 9 F C 10	rondella/washer	1 1 1 1
I 9	3240.008 9 FV 10	dado/nut	1 1 1 1
I 10	1760.029 9 D C 10	bullone/bolt M 6 X 1 X 30	1 1 1 1
I 11+	5202.060 500 S C 10	leva/lever	1 1 1 1
I 12+	7565.004 9 F C 10	rondella/washer	1 1 1 1
I 13:	3240.008 9 FV C 10	dado/nut	1 1 1 1
I 14	=8576.025 500 DVAC	SUPPLEMENTO COPPIA/EXTRA FUEL DEVICE (Pos. 13-14)	1 1 1 1
I 15	5655.038 500 SVAC 10	molla regolatore/governor spring	1 1 1 1
I 16+	.....	vedi/see Pos. 29	
I 17+	8420.002 9 S C 10	spina/locating pin	1 1 1 1
I 18	9730.010 9 S 10	vite/screw M 6 X 1 X 16	2 2 2 2
I 19	5801.467 5000 SVAC 10	molla/spring	1 1 1 1
I 20+	5200.560 5000 N A	leva/lever	1 1 1 1
I 21	.....		
I 22	3240.009 9 FV C 10	dado/nut	2 2 2 2
I 23	=2690.301 5000 S A	CONTROLLO A DISTANZA/REMOTE CONTROL (Pos. 7-8-11-20-23)	1 1 1 1
I 24	.....	vedi/see Pos. 25	
I 25	5830.119 10 FV C 10	morsetto/terminal	1 1 1 1
I 26+	3240.008 9 FV 10	dado/nut	1 1 1 1
I 27+	.....	vedi/see Pos. 29	
I 28+	5680.043 500 S C 10	molla/spring	1 1 1 1
I 29	=8785.075 500 S AC	SUPPORTO LEVA/LEVER SUPPORT (Pos. 12-16-17-26-27-28-29-30-31-32)	1 1 1 1
I 30+	1200.087 9 FV C 10	anello OR/rubber oil seal	1 1 1 1
I 31+	.....	vedi/see Pos. 29	
I 32+	.....	vedi/see Pos. 29	
I 33	1970.265 5000 N A 10	bussola/sleeve	1 1 1 1
L 1	3617.020 2760 S C 10	fascetta/strip fixing	1 1 1 1
L 2	9601.044 5000 FV C 10	tubo sfiato/breather pipe (mm 500)	1 1 1 1
L 3	2145.003 2830 FV C	cappuccio/cap	1 1 1 1
L 4+	8506.003 904 S C 10	squadretta/angle bracket	1 1 1 1
L 5+	9730.034 9 F C 10	vite/screw M 8 X 1,25 X 55	2 2 2 2
L 6	=9050.050 530 FVIC	TAPPO SFIATO/BREATHING CAP (Pos. 6-7)	1 1 1 1
L 7+	1200.014 9 FV C 10	anello OR/rubber oil seal	1 1 1 1
L 8	7625.212 9 N 10	rondella/washer	2 2 2 2
L 9	3230.030 9 SV C 10	dado lato distrib./gear side nut M 8	2 2 2 2
L 10	=2125.141 520 S C	CAPPELLO BILANC./ROCKER BOX CAP (Pos. 4-5-10)	1 1 1 1
L 11	3240.077 9 N 10	dado prig.fiss.testa l.vol./nut M 9	2 2 2 2
L 12	7565.010 9 F C 10	rond.prig.fiss.testa lato vol./washer	2 2 2 2
L 13+	9850.048 500 S C 10	vite/screw	1 1 1 1
L 14+	3240.008 9 FV 10	dado/nut	1 1 1 1
L 15+	3240.008 9 FV 10	dado/nut	1 1 1 1
L 16+	9850.048 500 S C 10	vite/screw	1 1 1 1
L 17	4400.023 540 FV C 50	guarnizione/gasket 0,50	1 1 1 1
L 18	=9200.131 540 S C	TESTA/CYLINDER HEAD (decompr.fitting) (Pos. 18-21-25-26-27-28-30-31-32-34-35-36-37-F 13)	1 1 1 1
L 19	7625.212 9 N 10	rondella l.vol./flywheel side washer	2 2 2 2
L 20	3240.076 9 FV C 10	dado lato volano/flywheel side nut	2 2 2 2
L 21+	6780.068 9 S C 10	prigioniero/stud M 8 X 18 (30)	2 2 2 2
L 22	=4330.048 550 S C	GRUPPO BIL./ROCKER ARM ASS.Y (Pos. 13-14-15-16-22-23-24)	1 1 1 1
Motore/Engine 6LD 325 K - AGR. Versione/Version 710104			
" " 6LD 360 K - AGR. " " 722072			
" " 6LD 400 K - AGR. " " 718892			
" " 6LD 435 K - AGR. " " 727690			



Pos.	Matricola/Part No.	Note/Remarks	Q.ty/Eng.				
L 23+	6045.039	540 DV C	perno/locket arm shaft	1	1	1	1
L 24+	.....		vedi/see Pos. 22				
L 25+	6780.010	9 F 10	prigioniero/stud M 8 X 22 (34)	1	1	1	1
L 26+	6780.071	9 SV C 10	prigioniero/stud M 8 X 28 (40)	1	1	1	1
L 27+	8000.036	283 FV CR10	sede v.aspiraz./inlet v.seat	1	1	1	1
L 28+	8000.037	283 FV CR10	sede v.scarico/exhaust v.seat	1	1	1	1
L 29	1160.008	500 FV C 10	anello/circlip	2	2	2	2
L 30+	6410.036	500 F C 10	piattello/retainer with half-collets	2	2	2	2
L 31+	5755.045	500 FV C 10	molla/spring	2	2	2	2
L 32+	4845.166	500 FVICR10	guida v.asp./inlet v.guide	1	1	1	1
"	4845.167	500 FVICR10	" " " std.	1	1	1	1
L 23	4730.200	520 N 10	guarnizione testa/head gasket +0,50	1	1	1	1
"	4730.159	520 N 10	" " " 0,55	1			
"	4730.207	520 N 10	" " " 0,60	1			
"	4730.160	520 SV C 10	" " " 0,65	1			
"	4730.208	520 N 10	" " " 0,70	1			
"	4730.161	520 N 10	" " " 0,75	1			
"	4730.209	520 N 10	" " " 0,80	1			
"	4730.162	520 N 10	" " " 0,85	1			
"	4730.210	520 N 10	" " " 0,90	1			
"	4730.210	520 N 10	" " " 0,95	1			
"	4730.163	520 N 10	" " " 1,00	1			
"	4730.171	530 SV C 10	" " " 0,50		1		
"	4730.180	530 SV C 10	" " " 0,55		1		
"	4730.145	530 SV C 10	" " " 0,60		1		
"	4730.181	530 SV C 10	" " " 0,65		1		
"	4730.146	530 SV C 10	" " " 0,70		1		
"	4730.182	530 SV C 10	" " " 0,75		1		
"	4730.147	530 SV C 10	" " " 0,80		1		
"	4730.183	530 SV C 10	" " " 0,85		1		
"	4730.148	530 SV C 10	" " " 0,90		1		
"	4730.184	530 SV C 10	" " " 0,95		1		
"	4730.130	540 SV C 10	" " " 0,50			1	1
"	4730.175	540 SV C 10	" " " 0,55			1	1
"	4730.122	540 SV C 10	" " " 0,60			1	1
"	4730.176	540 SV C 10	" " " 0,65			1	1
"	4730.123	540 SV C 10	" " " 0,70			1	1
"	4730.177	540 SV C 10	" " " 0,75			1	1
"	4730.124	540 SV C 10	" " " 0,80			1	1
"	4730.178	540 SV C 10	" " " 0,85			1	1
"	4730.133	540 DV C 10	" " " 0,90			1	1
"	4730.179	540 DV C 10	" " " 0,95			1	1
L 34+	4845.168	500 FVACR10	guida v.scar./exhaust v.guide +0,50	1	1	1	1
"	4845.169	500 FVACR10	" " " +0,50	1	1	1	1
L 35+	9652.040	520 FV CR	valvola aspirazione/inlet valve	1	1	1	1
L 36+	9685.051	520 FV CR	valvola scarico/exhaust valve	1	1	1	1
L 37+	3430.070	500 FV C 10	fondello/cup	2	2	2	2
M 1	6960.069	500 FV C	puleggia/pulley	1	1	1	1
M 2	1765.053	9 F C 10	bullone/bolt M 7 X 1 X 24	4	4	4	4
M 3	4055.003	283 F C	fune avviamento/rope starting	1	1	1	1
N 1	=8180.092	520 FV CR	SERIE GUARNIZIONI/GASKET SET	1			
"	=8180.082	530 FV CR	" " " "	1	1		
"	=8180.063	540 SV CR	" " " "			1	1
(Pos.A 9-A10-E 7-F51-H16-H31-L17-L33)							
Motore/Engine 6LD 325 K - AGR. Versione/Version 710104 ..... " " 6LD 360 K - AGR. " " 722072 ..... " " 6LD 400 K - AGR. " " 718892 ..... " " 6LD 435 K - AGR. " " 727690 .....							
LOMBARDINI MOTORI F.I.M. S.p.a.				Edizione del/Issue of 15.05.1992			

INDICE DELLE MODIFICHE/IMPROVEMENTS INDEX

Motori/Engines Gr. 6-K.AGR.



Pos.	Nuova matricola New Part No.	Vecchia matricola Old Part.No.	Vedi Circ.Tec. See Serv.Lett.	Q.ty/Eng.
B 2	8480.075 530 S IC	8480.023 500	60019,60020	1 1 1
"	8480.060 540 D IC	8480.030 395	60008	1 1 1
B 4	6500.808 520 FVAC	6500.318 520	60020	1 1 1
"	6500.809 520 F ACR	6500.319 520	60020	1 1 1
"	6500.810 520 F ACR	6500.320 520	60020	1 1 1
"	6500.733 530 FVAC	6500.238 530	60019	1 1 1
"	6500.734 530 F ACR	6500.239 530	60019	1 1 1
"	6500.735 530 F ACR	6500.238 530	60019	1 1 1
"	6500.730 540 FVAC	6500.150 540	60008	1 1 1
"	6500.731 540 F ACR	6500.151 540	60008	1 1 1
"	6500.732 540 F ACR	6500.152 540	60008	1 1 1
B 8	2380.299 520 FVAC	2380.177 520	60020	1 1 1
"	2380.275 530 FVAC	2380.172 530	60019	1 1 1
"	2380.298 540 FVAC	2380.132 540	60008	1 1 1
C 4	8675.135 500 F AC	8675.082 500	9104	1 1 1
C 6	9880.129 540 N A	9880.305 540	60023	1 1 1
D 2	9520.029 500 FVAC	9520.046 500	60008,60019, 60020	1 1 1
D 12	8245.009 9 F AC 10	8245.010 9	9102	6 6 6
D 14	=7362.193 500 S AC	7362.109 500	9103	1 1 1
D 14	4936.020 500 F AC	4936.047 540	9102	1 1 1
D 15	2086.100 500 S A	2085.072 500	9103	1 1 1
D 16	7701.081 500 N A 10	.....	9103	1 1 1
F 40	=6590.136 520 D IC	6590.074 520	9110	1 1 1
F 56	9672.029 540 D AC	9672.012 500	9110	1 1 1
G 1	5066.111 540 N A	5066.053 540	60008,60019, 60020	1 1 1
G 2	5066.112 540 N A	5066.054 540	60008,60019, 60020	1 1 1
G 9	5725.043 540 N A	.....	60008,60019, 60020	1 1 1
H 3	6140.351 530 FVAC	6141.046 500	9102	1 1 1
H 4	=6605.066 530 SVAC	6605.064 520	9102	1 1 1
H 6	5200.363 500 S AC 10	5200.176 540	9102	1 1 1
H 7	3203.050 9 N A 10	.....	9102	1 1 1
H 13	5801.198 540 SVAC 10	5801.087 540	9102	1 1 1
H 17	9730.009 9 D AC 10	.....	9102	1 1 1
H 18	7565.004 9 F AC 10	.....	9102	1 1 1
H 19	6371.045 500 N A 10	.....	9102	1 1 1
I 2	.....	7565.004 9	60017	2 2 2 2
I 3	8900.338 5000 D A	8903.043 5000	60017	1 1 1 1
I 14	=8576.025 500 DVAC	8576.016 540	9101	1 1 1 1
I 15	5655.038 500 SVAC 10	5655.091 540	9102	1 1 1 1
I 19	5801.467 5000 SVAC 10	5655.036 710	60017	1 1 1 1 1
I 20+	5200.560 5000 N A	5204.083 5000	60017	1 1 1 1 1
I 21	.....	9180.011 70	60017	2 2 2 2 2
I 23	=2690.301 5000 S A	2691.082 5000	60017	1 1 1 1 1
I 29	=8785.075 500 S AC	8785.076 540	9102	1 1 1 1 1
I 33	1970.265 5000 N A 10	.....	60017	1 1 1 1 1
L 6	=9050.050 530 FVIC	9050.021 270	5153	1 1 1 1
L 24	4845.166 500 FVICR10	4845.071 500	9117	1 1 1 1
"	4845.167 500 FVICR10	4845.075 500	9117	1 1 1 1
L 32	4845.168 500 FVACR10	4845.030 500	9118	1 1 1 1
"	4845.162 500 FVACR10	4845.052 500	5118	1 1 1 1
Motore/Engine 6LD 325 K - AGR. Versione/Version 710104				
" " 6LD 360 K - AGR. " " 722072				
" " 6LD 400 K - AGR. " " 718892				
" " 6LD 435 K - AGR. " " 727690				
LOMBARDINI MOTORI F.I.M. S.p.a.				Edizione del/Issue of 15.05.1992



Gruppo motori	Tipo	pag. 1/2	
Groupe moteurs	Type	6LD 325 - 360 - 400 - 435	
Engine group	Type	6	6LD 325 K.AGR - 360 K.AGR - 400 K.AGR - 435 K.AGR
Motorgruppe	Typ	6LD 401/B1 - 435/B1	
Grupo motores	Tipo		

- Avviatore autoavvolgente: aggiunte molle di richiamo per denti d'innesto - Migliorie funzionali.
- Démarrage auto-enrouleur: adjunction des ressorts de rappel pour dents d'embrayage - Améliorations fonctionnelles.
- Self rewind starter: new return springs for starter teeth - Functional improvements.
- Neuer Reversierstarter: Feder für Auffrollvorrichtung und Mitnehmer - Funktionsverbesserung.
- Arranque recuperable: se añade muelle de retorno gatillo embrague - Mejoría funcional.

Antemodifica  
Avant la modification  
Prior to improvement  
Vor der Änderung  
Antes de la modificación

Postmodifica  
Après la modification  
After improvement  
Nach der Änderung  
Después de la modificación

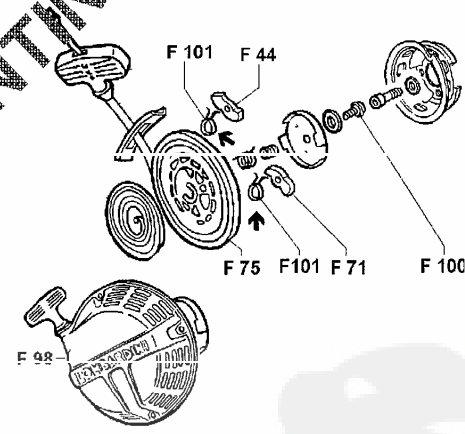
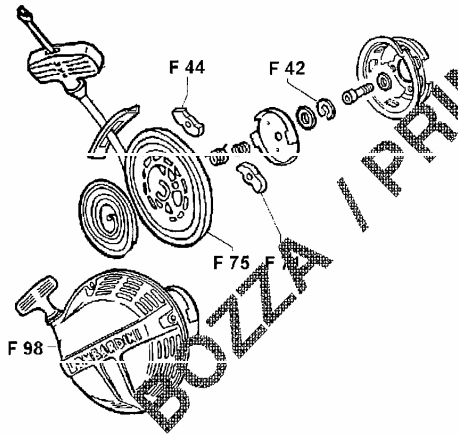
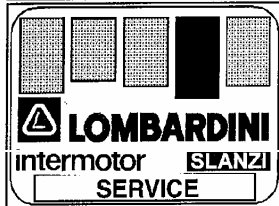

FIG.	MATR./REF./P.NO	Q.ty	FIG.	MATR./REF./P.NO	Q.ty
F 42	1165.006 9 B	1	-	-	-
F 44	5025.094 196 B	1	F 44	5025.097 196 A	1
F 71	5025.094 196 B	1	F 71	5025.097 196 A	1
F 75	7100.371 196 B	1	F 75	7100.377 196 A	1
F 98	1472.026 500 E	1	F 98	1472.034 500 I	1
			F100	9730.340 9 A	1
			F101	5660.078 196 A	2

Attuazione da  
A partir de  
Starting from .....  
Gültig ab  
Actualización desde



CIRCOLARE TECNICA  
CIRCULAIRE TECHNIQUE  
SERVICE LETTER  
TECHNISCHES RUNDSCHREIBEN  
CIRCULAR TECNICA

Compilazione <i>M. Imbella</i>	Sez. Sect. 60
	N. .... 60052
visto/approvazione <i>Marco B...</i>	Data .....
Modello 50722	M.A.T. 50231

C.T. 60052		pag. 2/2	
<p>L'aggiunta delle molle di richiamo Pos. F101 per denti d'innesto ha comportato le seguenti modifiche:</p> <ul style="list-style-type: none"><li>- puleggia Pos. F 75: variata l'altezza del mozzo da 34,5 a 35,5 e modificati i perni per denti d'arresto;</li><li>- sul perno centrale della scatola autoavvolgente F 98 (non fornita sciolta), è stata eliminata la sede per anello benzing Pos. F 42 e sostituita con filettatura; il fermo assiale è ottenuto tramite la vite flangiata M 5 X 10 matr. 9730.340 Pos. F100.</li></ul> <p>I singoli particolari ante e postmodifica non sono tra loro intercambiabili. Gli autoavvolgenti completi antemodifica sono sostituiti da quelli postmodifica, a cui è stato variato il codice per motivi gestionali.</p> <p>L'adjonction des ressorts pos. F 101 pour les dents d'embrayage a demandé les modifications suivantes:</p> <ul style="list-style-type: none"><li>- poulie pos. F 75: modification de la longueur du moyeu de mm 34,5 à 35,5 et modification des goujons pour les dents d'arrêt;</li><li>- Sur le goujon central de la boîte auto-enrouleur pos. F 98 (qui n'est pas livrée séparément), le siège pour la bague benzing pos. F 42 a été éliminé et il a été remplacé par un filetage. L'arrêt axial est obtenu par la vis M 5 X 10 réf. 9730.340 pos. F 100.</li></ul> <p>Les pièces séparées avant et après la modification ne sont pas interchangeables entre elles. Les auto-enrouleurs complets avant la modification sont remplacés par les nouveaux, dont la référence a été changée pour des motifs de gestion.</p> <p>The introduction of the new return springs Pos. F 101 for starter teeth requires the following modifications:</p> <ul style="list-style-type: none"><li>- pulley Pos. F 75: hub lenght modified from 34,5 to 35,5 mm; modification of pawl pins.</li><li>- elimination of benzing ring seat Pos. F 42 on central pin of rewind box Pos. F 98 (not supplied loose), superseded by threading; the axial stop is obtained by the flanged screw M 5 X 10 P.No. 9730.340 Pos. F 100.</li></ul> <p>The single prior to/after improvement parts are not interchangeable. The complete old self-rewinders are superseded by the new ones, whose ref.No has been changed for handling reasons.</p> <p>Die Einführung der neuen Feder Pos. F 101 für die Mitnehmerklinken erfordert folgende Änderungen:</p> <ul style="list-style-type: none"><li>- Aufrollscheibe Pos. F 75, der Achse von 34,5 auf 35,5 mm und der Mitnehmerklinken;</li><li>- der Begrenzungsring F 42 entfällt auf dem zentralen Stift in dem Gehäuse F 98 (einzeln nicht lieferbar); der Begrenzungsring wird ersetzt durch eine Schruabe M 5 X 10 Pos. F 100.</li></ul> <p>Die Einzelteile vor und nach Änderung sind einzeln nicht austauschbar. Der kompl.Reversierstarter wird ersetzt durch den neuen, der eine neue E-teilnr. bekommen hat.</p> <p>La inclusión de los muelles de retorno pos. F 101 para el gatillo embrague arranque recuperable ha comportado los cambios siguientes:</p> <ul style="list-style-type: none"><li>- polea pos. F 75, se modifica la altura del cubo de 34,5 a 35,5 mm. y se modifican los tetones para los gatillos de paro.</li><li>- en el eje central de la caja exterior arranque recuperable pos. F 98 (que no se suministra suelta), se ha eliminado la ranura para el anillo benzing pos. F 42, que se sustituye por un agujero roscado; el bloqueo axial se consigue a través del tornillo de centrado M 5 X 10, matr. 9730.340, pos. F 100.</li></ul> <p>Las piezas de recambio anteriores y posteriores a la modificación no son intercambiables unitariamente entre si, deberán sustituirse en conjunto.</p> <p>Los arranques recuperables completos anteriores a la modificación pueden ser sustituidos por los posteriores a la modificación y que han sido variados los códigos por motivos de gestión.</p>			
Tavole ricambi interessate alla modifica: Tableaux pièces détachées concernant la modification: Improvement applies to the following spare parts table: Von der Änderung betroffene Ersatzteillisten: Tablas repuestos referidas a la modificación:		1.5302.497	

CATALOGO ACCESSORI/ACCESSORIES CATALOGUE

Tavola/Table .. . . .

Accessorio di completamento  
Completion accessory

Motori/Engines  
Gr. 6  
Disegno  
Drawing

ATTACCO COFANO/SPECIAL GOLDONI FITTING SHROUD

9993.722

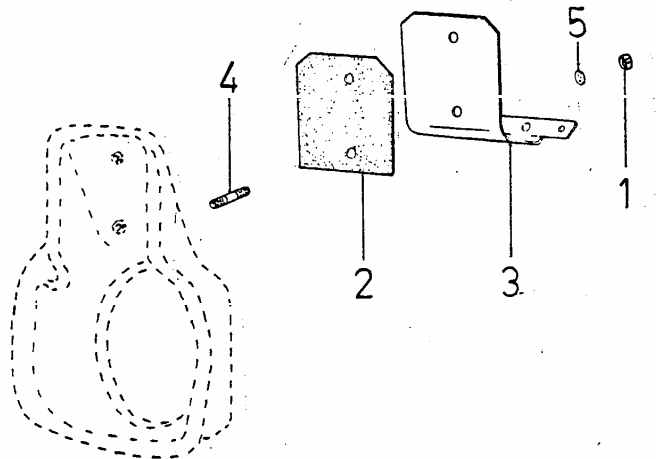

Pos.	In aggiunta To add	Descrizione Description	'Q.tà' 'Q.ty'	M	In detrazione To delete
1	9.3203.047	dado/nut	2		
2	5000.4570.024	guarnizione/rubber shim	1		
3	5000.6357.059	piastra/plate	1		
4	9.6780.008	prigioniero/stud	2		
5	9.7625.061	rondella/washer	2		

M Modifiche/Improvements

CATALOGO ACCESSORI/ACCESSORIES CATALOGUE	Tavola/Table	.....
Accessorio di completamento Completion accessory	Motori/Engines Gr. 4	Disegno Drawing
ASTA LIVELLO CORTA/SHORT DIP STICK		9997.033

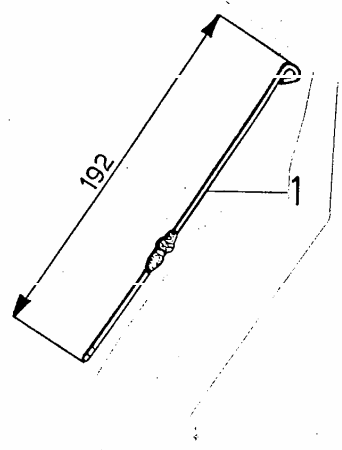

Pos.	In aggiunta To add	Descrizione Description	'Q.tà' M 'Q.ty'	In detrazione To delete
1	5000.1400.072	asta livello/dip stick	1	500.1400.035

M Modifiche/Improvements



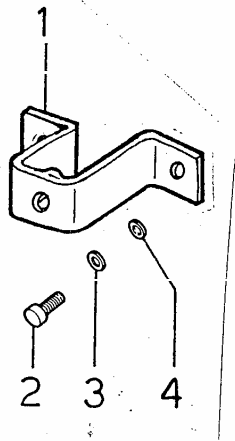

CATALOGO ACCESSORI/ACCESSORIES CATALOGUE	Tavola/Table	.....
Accessorio di completamento Completion accessory	Motori/Engines Gr. 6	Disegno Drawing
DISTANZIALE PER SERBATOIO COMBUSTIBILE/FUEL TANK SPACER		9993.685

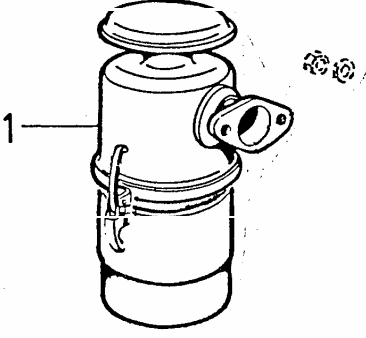

Pos.	In aggiunta To add	Descrizione Description	Q.tà Q.ty	M	In detrazione To delete
1	5000.2183.082	cavallotto/spacer	1		
2	9.9732.064	vite/screw	2		
3	9.7565.007	rondella/washer	2		
4	9.7625.061	rondella/washer	2		

M Modifiche/Improvements

CATALOGO ACCESSORI/ACCESSORIES CATALOGUE			Tavola/Table .. . . .		
Accessorio di completamento Completion accessory			Motori/Engines Gr. 6		Disegno Drawing
FILTRO ARIA A BAGNO D'OLIO/OIL BATH AIR CLEANER					9993.433
					
Pos.	In aggiunta To add	Descrizione Description	Q.tà Q.ty	M	In detrazione To delete
1	540.3700.111	filtro completo/air cleaner ass.y  Per componenti interno del filtro vedi tavola base  Air cleaner spare parts: see base table	1		
M Modifiche/Improvements					
 <b>LOMBARDINI</b> - Italy			Data 20/07/1989		

CATALOGO ACCESSORI/ACCESSORIES CATALOGUE		Tavola/Table	.. ....
Accessorio di completamento Completion accessory		Motori/Engines 6LD360 - 400	Disegno Drawing
CONVOGLIATORE CON ATTACCHI COFANO/FITTING HOOD SHROUD			9993.284

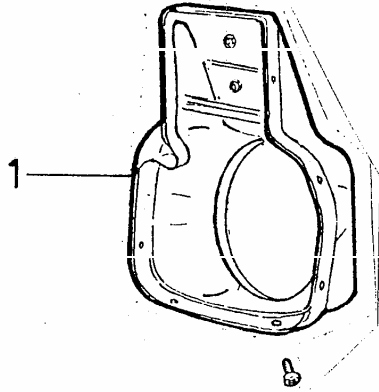

Pos.	In aggiunta To add	Descrizione Description	Q.tà M Q.ty	In detrazione To delete
1	5300.2569.142	convogliatore/shroud	1	540.2569.058

M Modifiche/Improvements

CATALOGO ACCESSORI/ACCESSORIES CATALOGUE	Tavola/Table	.. ....
Accessorio di completamento Completion accessory	Motori/Engines Gr. 6	Disegno Drawing
PROTEZIONE TAPPO SFIATO/BREATHER CAP GUARD		9990.129

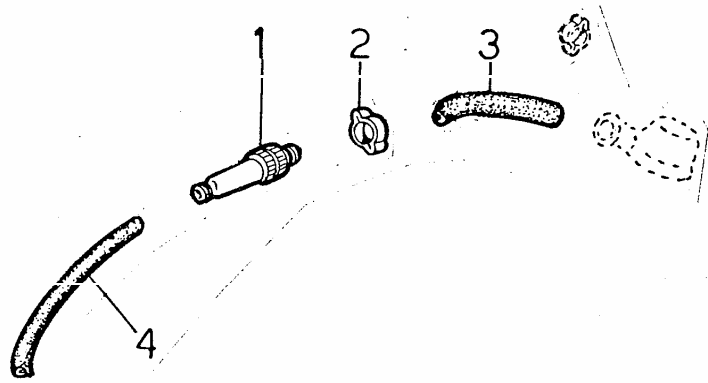

Pos.	In aggiunta To add	Descrizione Description	'Q.tà' 'Q.ty'	M	In detrazione To delete
1	5000.3730.065	filtro antipolvere/dust filter	1		
2	9.3630.009	fascetta/clamp Oetiker 1517	2		
3	2830.9599.037	tubo/pipe	1		
4	5000.9599.038	tubo/pipe	1		5000.9601.044

M	Modifiche/Improvements				
---	------------------------	--	--	--	--



CATALOGO ACCESSORI/ACCESSORIES CATALOGUE		Tavola/Table	.. ....
Accessorio di completamento Completion accessory		Motori/Engines Gr. 6	Disegno Drawing
MARMITTA SCARICO/EXHAUST MUFFLER			9972.097

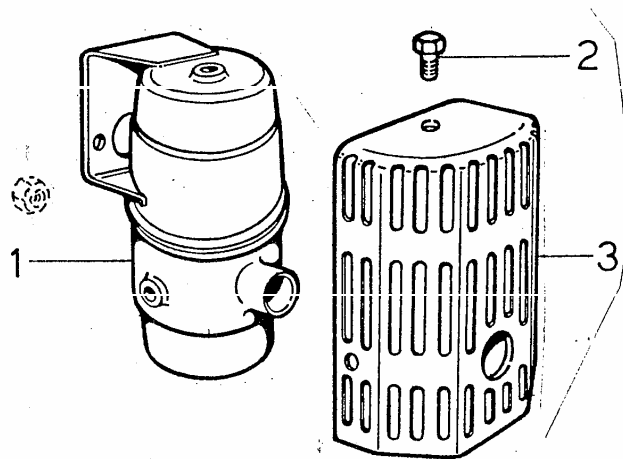

Pos.	In aggiunta To add	Descrizione Description	Q.tà M Q.ty	In detrazione To delete
1	5000.5462.094	marmitta/exhaust muffler	1	500.5462.097
2	9.9790.037	vite/screw M 6 X 8	3	
3	5000.6927.048	protezione/muffler guard	1	

M Modifiche/Improvements

CATALOGO ACCESSORI/ACCESSORIES CATALOGUE	Tavola/Table	.. . . .
Accessorio di completamento Completion accessory	Motori/Engines Gr. 6	Disegno Drawing
PATTINO PROTEZIONE MOTORE/ENGINE GUARD PAD		9984.086

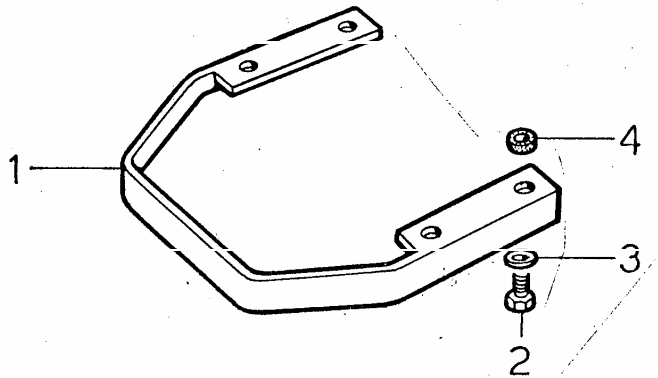

Pos.	In aggiunta To add	Descrizione Description	Q.tà M Q.ty	In detrazione To delete
1	5000.6010.066	pattino/guard pad	1	
2	9.1770.007	bullone/bolt M 8 X 18	4	9.1770.i11
3	9.7625.012	rondella/washer	4	
4	720.3527.004	distanziale/spacer	4	

M Modifiche/Improvements

Gruppo motori	6	Motori con alternatore 12 V
Groupe moteurs		Moteurs équipés avec alternateur 12 V
Engines group		12 V voltage alternator equipped engines
Motorgruppe		Motoren mit Drehstrom Generator 12 V
Grupo motores		Motores equipados con alternador 12 V

Causa : Migliorie funzionali (raffreddamento).  
 Cause : Améliorations fonctionnelles (refroidissement)  
 Reason : Functional improvements (cooling).  
 Ursache : Betriebsverbesserung (Kühlung).  
 Causal : Mejoras funcionales (refrigeración).

Antemodifica  
 Avant la modification  
 Prior to improvement  
 Vor der Aenderung  
 Antes de la modificacion

Postmodifica  
 Après la modification  
 After improvement  
 Nach der Aenderung  
 Después de la modificacion

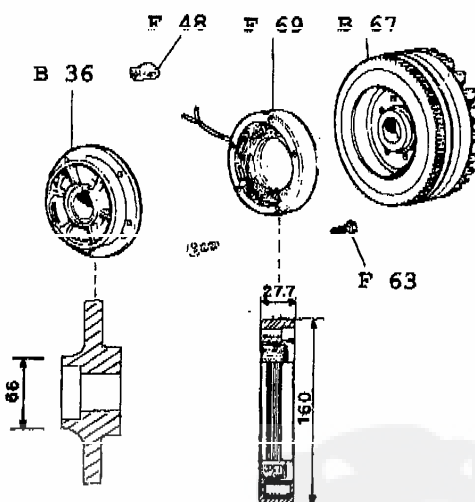
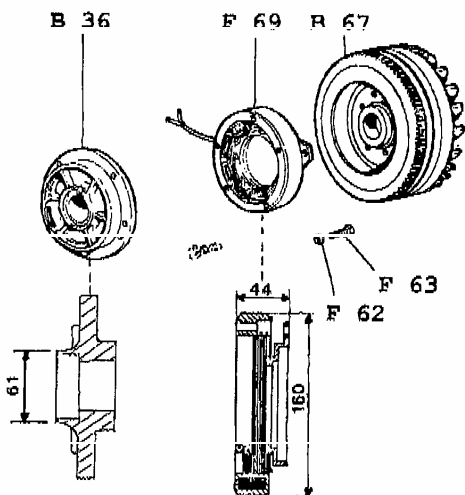

FIG.	MATR./REF./P.NO.	Q.ty
B 36	500.8675.150 S BC	1
B 67	540.9880.144 S BC	1
F 62	9.7555.004 FVBC 10	3
F 63	9.1760.001 FVB 10 M 6 X 10	3
F 69	283.1157.153 FVBC (12V-12A) (3)	1
"	5600.1157.041 FVBC (12V-16A) (2)	1

FIG.	MATR./REF./P.NO.	Q.ty
B 36	540.8675.193 S AC	1
B 67	540.9880.666 N A	1
F 4R	530.3617.046 M A	1
F 63	9.9731.022 N A M 5 X 20	4
F 69	629.1157.154 FVAC (12V-12A) (3)	1
"	5600.1157.167 F T (12V-16A) (2)	1

Attuazione da	6LD 260	... 3064011	(3) 3 fili
A partir de	6LD 325	... 3063082	(2) 2 fili
Starting from	6LD 360	... 3063172	
Gültig ab	6LD 400	... 3063772	
Actualización desde			



CIRCOLARE TECNICA  
 CIRCULAIRE TECHNIQUE  
 SERVICE LETTER  
 TECHNISCHES RUNDSCHREIBEN  
 CIRCULAR TECNICA

ez. Sect. 60
N° 60007
9.10.1989
m. p. m. 5/98

I particolari antemodifica, non intercambiabili con quelli postmodifica, sono forniti ad esaurimento.

L'insieme dei particolari postmodifica sostituisce l'insieme di quelli antemodifica.

Les pièces avant la modification, qui ne sont pas séparément interchangeable avec les nouvelles, sont fournis jusqu'à l'épuisement.

L'ensemble des pièces après la modification remplace l'ensemble de celles avant la modification.

Prior to improvement parts are supplied until exhaustion and are not separately interchangeable with the new one.

After improvement parts as a whole supersede the prior to improvement set.

Die einzelnen ungeänderten Teile sind bis zum Vergriff lieferbar.  
Die Gesamtheit der neuen Teile ersetzt die alten Teile.

Los particulares antemodificación, no intercambiables singularmente con aquellos postmodificación, serán suministrados hasta su agotamiento.  
El conjunto de particulares postmodificación reemplaza el conjunto de aquellos antemodificación.

+-----+-----+-----+		
! Pubblicazioni tecniche interessate alla modifica:		
! Publications techniques concernant la modification:		
! Improvement applies to the following technical publications:		
! Von der Änderung betroffene technische Veröffentlichungen:		
! Publicaciones técnicas referidas a la modificación:		
+-----+-----+-----+		
! Tavola Ricambi	! Catalogo Accessori	! Catalogo Kit Ricambi
! Tabl.Pièces Dét.	! Catalogue Accessoires	! Catalogue Kit-Rechang.
! Spare Parts Table!	! Accessories Catalogue	! Sp.Parts-Kit Catalogue
! Ersatzteiltafel	! Zubehoerkatalog	! Ersatzteilgruppenkat.
! Tabla Repuestos	! Catalogo Accesorios	! Catalogo Kit-Repuestos
+-----+-----+-----+		
! 1.5302.497		
+-----+-----+-----+		